



Cambridge International Examinations
Cambridge International General Certificate of Secondary Education

CANDIDATE
NAME

CENTRE
NUMBER

--	--	--	--	--	--

CANDIDATE
NUMBER

--	--	--	--	--



DESIGN AND TECHNOLOGY

0445/31

Paper 3 Resistant Materials

October/November 2016

1 hour

Candidates answer on the Question Paper.

No Additional Materials are required.

READ THESE INSTRUCTIONS FIRST

Write your Centre number, candidate number and name on all the work you hand in.

Write in blue or black pen.

You may use an HB pencil for any diagrams, graphs or rough working.

Do not use staples, paper clips, glue or correction fluid.

DO NOT WRITE IN ANY BARCODES.

Section A

Answer **all** questions in this section.

Section B

Answer **one** question in this section.

You may use a calculator.

At the end of the examination, fasten all your work securely together.

The number of marks is given in brackets [] at the end of each question or part question.

The total of the marks for this paper is 50.

This document consists of **19** printed pages and **1** blank page.

Section A

Answer **all** questions in this section.

- 1 Complete the table below by naming a specific material for each product.

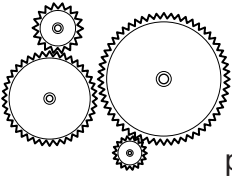
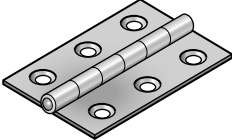
Product	Specific material
 <p data-bbox="512 651 639 680">metal can</p>	
 <p data-bbox="512 857 679 887">plastic gears</p>	
 <p data-bbox="292 1070 699 1099">metal hinge for an outside door</p>	

[3]

- 2 Add to the drawing below to show dovetail nailing.

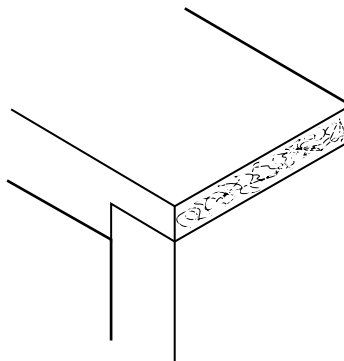

[2]

3 Fig. 1 shows an item of equipment used in a workshop.

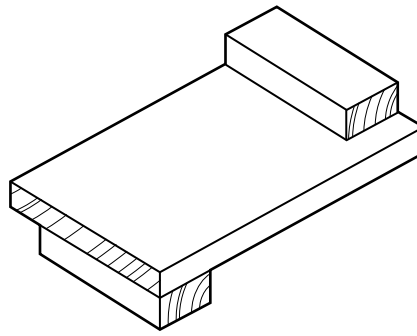

Fig. 1

(a) Name the item of equipment.

..... [1]

(b) Add a sketch to Fig. 1 to show how the item of equipment would be used. [2]

4 Complete the drawing below to show a tongue and groove joint.



[2]

5 Fig. 2 shows a commercially produced shelving system made from aluminium.

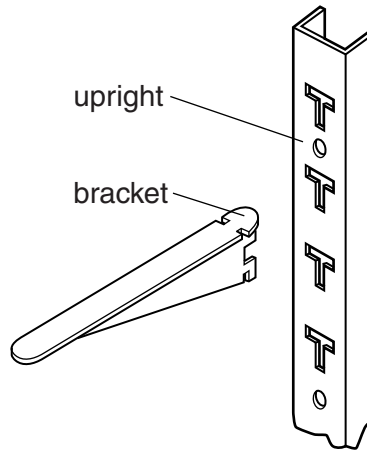

Fig. 2

(a) Name a process used to make the upright part of the shelving system.

..... [1]

(b) Name **two** finishes that could be applied to the aluminium shelving system.

1

2 [2]

6 Complete the table below by describing a specific use for each of the saws shown.

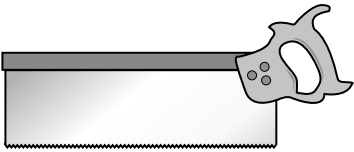
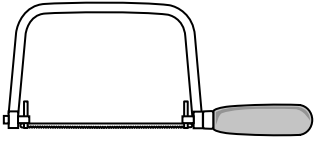
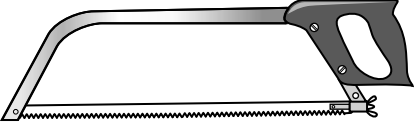
Saw	Specific use
	
	
	

[3]

7 Fig. 3 shows a joint marked out on wood and a mortise gauge that will be used to mark it out.

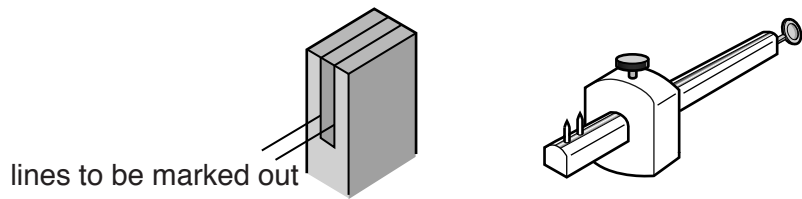

Fig. 3

Give **two** stages in setting the mortise gauge **before** the joint can be marked out.

Stage 1

Stage 2 [2]

8 Fig. 4 shows a handset that has been moulded to shape.

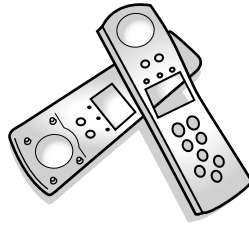

Fig. 4

Name a process that could be used to make the handset when made from:

(a) plastic

(b) metal [2]

9 Fig. 5 shows a piece of hardwood that will be used as a table top.

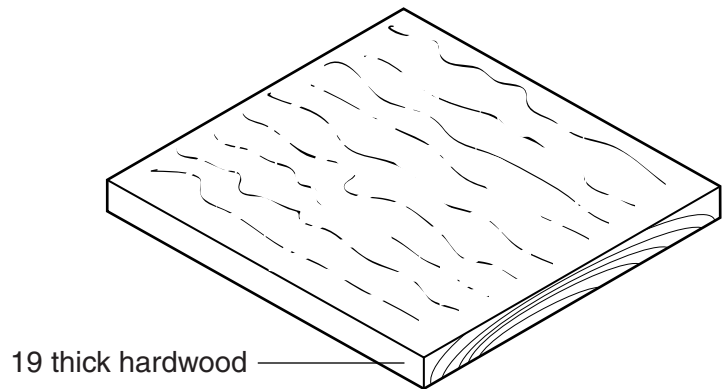

Fig. 5

Add to Fig. 5 to show **two** faults that could occur to the table top due to poor seasoning. [2]

10 Fig. 6 shows a woodworking process.

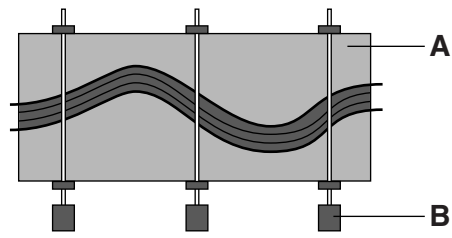

Fig. 6

(a) Name the process shown in Fig. 6.

..... [1]

(b) Name the items of equipment labelled **A** and **B**.

A

B [2]

Section B

Answer **one** question in this section.

- 11 Fig. 7 shows views of a small table that includes a magazine rack. The product is designed as flat-pack for self-assembly.

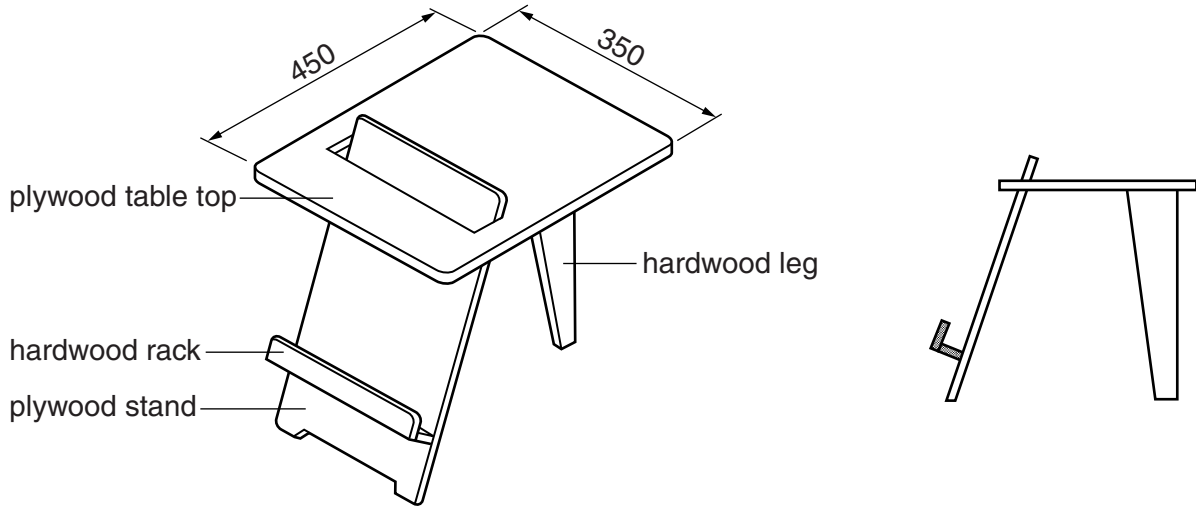

Fig. 7

- (a) Give **two** benefits to the user of buying self-assembly products.

- 1
- 2 [2]

(b) Fig. 8 shows part of the table top with a slot marked out ready to be cut out.

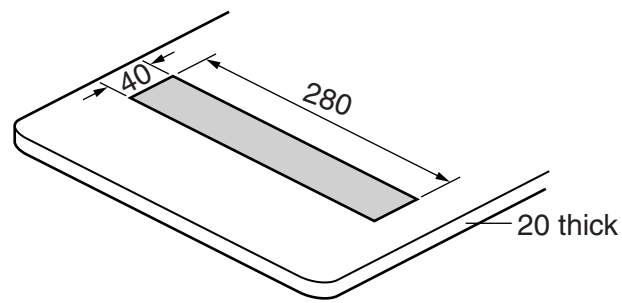

Fig. 8

Use sketches and notes to show how the slot could be cut out and the edges made flat and smooth.

[4]

(c) Use sketches and notes to show how the stand could be joined permanently to the table top as shown in Fig. 7.
Additional materials may be used.

[4]

- (d) Fig. 9 shows details of the end of the leg.
The leg will be joined to the underside of the table top by means of a glued dowel joint.

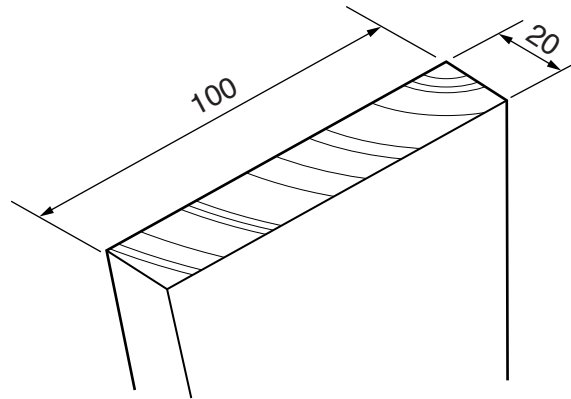

Fig. 9

- (i) State an appropriate diameter of dowel to be used.

..... [1]

- (ii) Draw on Fig. 9 to show the marking out with measurements for **two** holes to take the dowels. [2]

(e) Fig. 10 shows details of the stand and the rack.

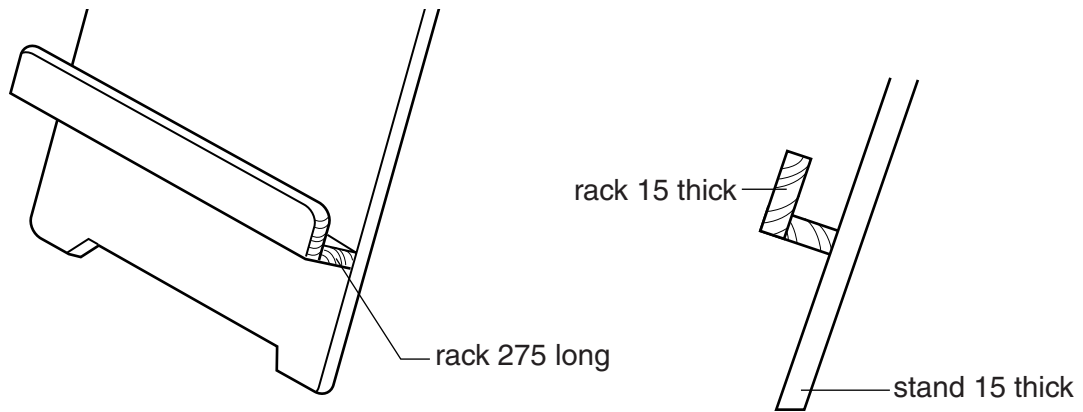

Fig. 10

Use sketches and notes to show how the rack could be screwed to the stand.

Give **four** details about the type of screw used to include:

- material;
- length;
- type of head;
- the number required.

(f) Fig. 11 shows two different designs of rack that could be used with the table.

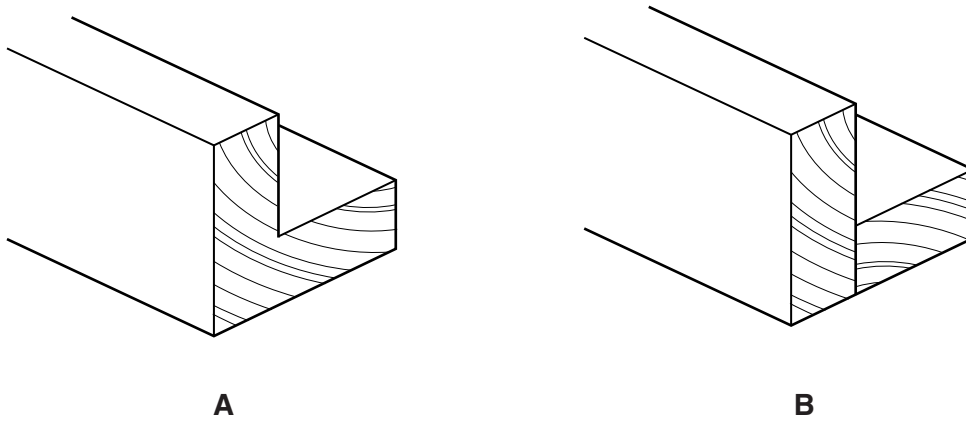

Fig. 11

(i) Decide which of the two designs, **A** or **B**, is stronger. Explain why.

.....

 [2]

(ii) Explain why design **A** could be considered wasteful in terms of materials used.

.....

 [2]

(g) Give **two** properties of a finish that would be applied to the table and magazine rack.

1
 2 [2]

12 Fig. 12 shows a desk tidy made from acrylic with a hardwood base.

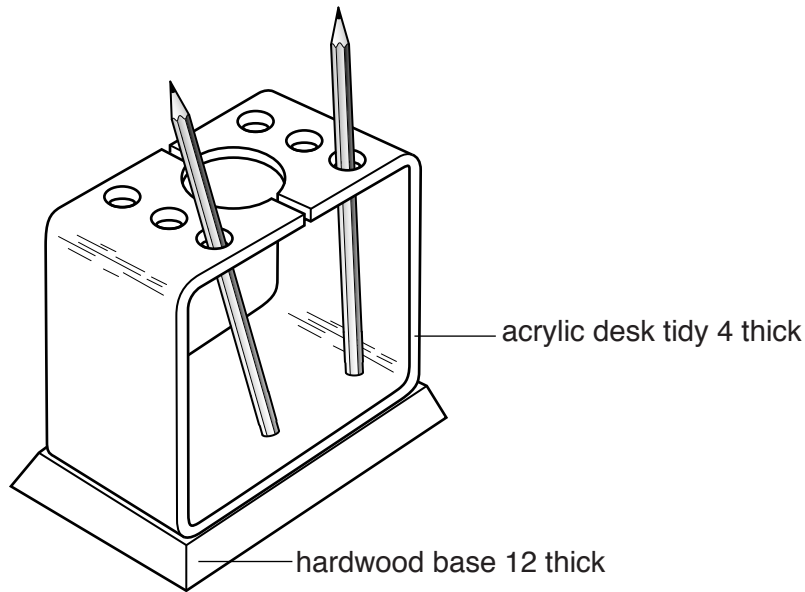

Fig. 12

(a) Give **two** properties of acrylic that make it suitable for the desk tidy.

1

2 [2]

(b) Give **two** items of research a designer would need to consider when designing the desk tidy.

1

2 [2]

(c) Give **two** reasons why the holes in the desk tidy would be drilled before the acrylic was bent to shape.

1

2 [2]

(d) Fig. 13 shows the development (net) of the desk tidy.

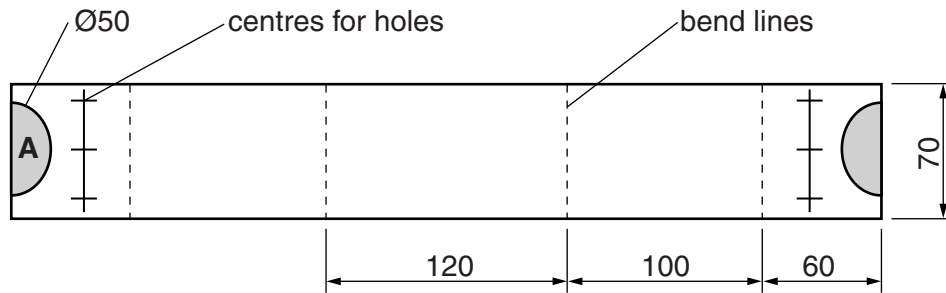

Fig. 13

Use sketches and notes to show how the shape at **A** could be cut out and the edges made smooth.

[3]

(e) Use sketches and notes to show how **one** of the bends shown in the development (net) could be produced.

Include the following details.

- the method of softening the acrylic
- the use of a former
- the method of retaining the shape while the acrylic cools

[4]

(f) Use sketches and notes to show modifications to the design of the desk tidy so that:

- the pencils do not slide about;
- a quantity of paper clips can be stored.

[4]

(g) Fig. 14 shows the hardwood used to make the base for the desk tidy. The base will have bevelled edges. Two bevelled edges are shown marked out.

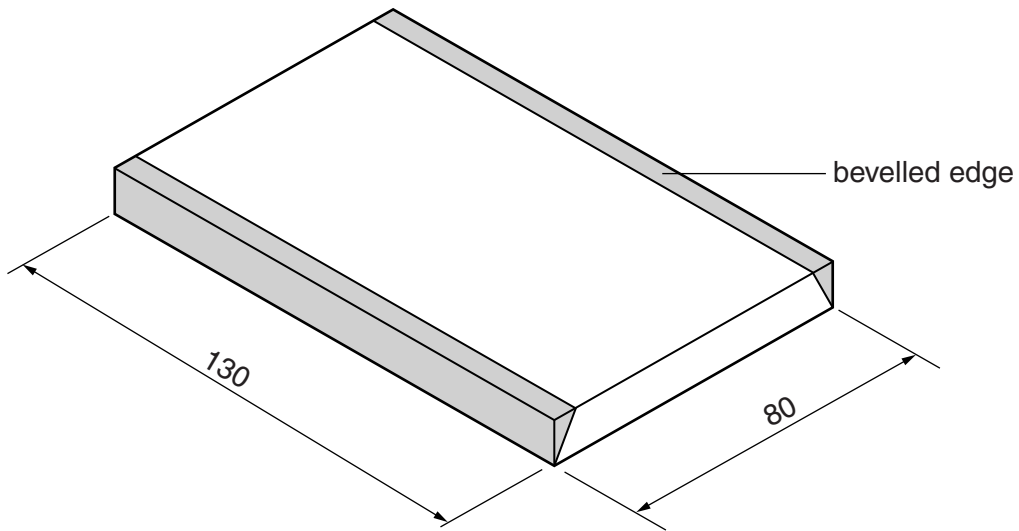

Fig. 14

(i) Give **one** benefit of using hardwood for the base of the desk tidy.

..... [1]

(ii) Suggest a suitable thickness for the hardwood base.

..... [1]

- (iii) Use sketches and notes to show how the **two** bevelled edges shown in Fig. 14 could be produced.

[3]

- (iv) Use sketches and notes to show how the acrylic desk tidy could be joined to the hardwood base without the use of an adhesive.

[3]

13 Fig. 15 shows an incomplete design for a bird feeder made from 1.5 thick aluminium sheet.

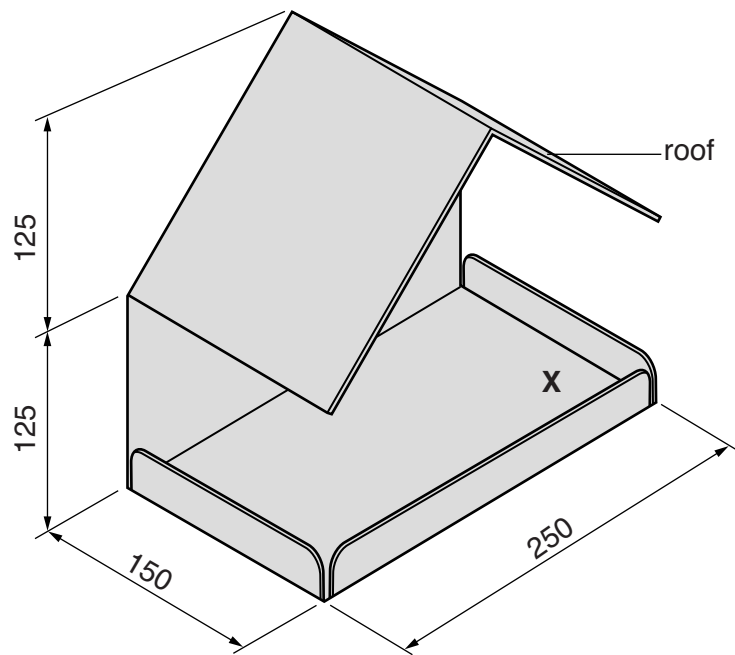

Fig. 15

(a) Give **two** reasons why aluminium is a good choice of material for the bird feeder.

- 1
- 2 [2]

(b) Fig. 16 shows part of the bird feeder, without the roof, marked out on a sheet of aluminium.

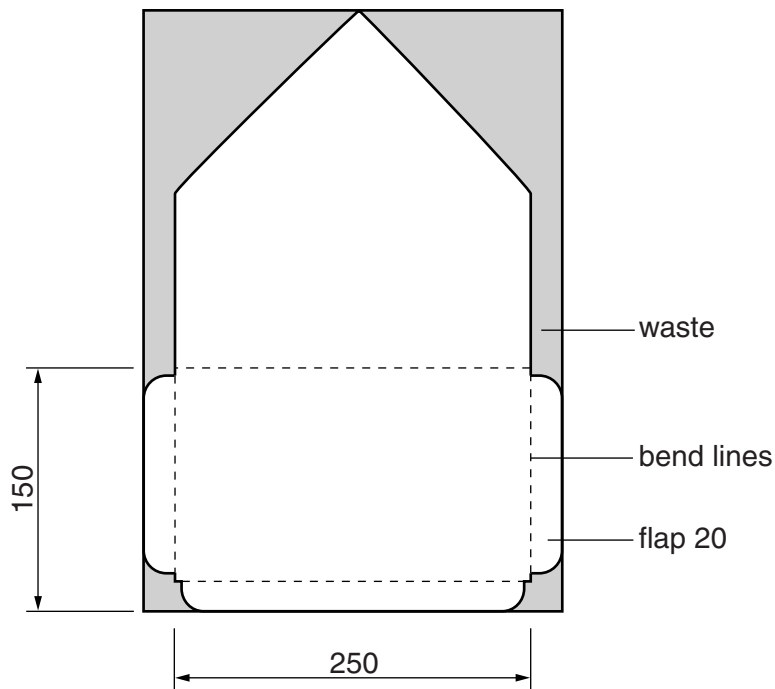

Fig. 16

(i) Name **two** marking out tools used to mark out the shape.

1

2 [2]

(ii) Use sketches and notes to show how the shape could be cut out from the sheet.

[3]

(iii) Use sketches and notes to show how the aluminium would be bent to shape along the bend lines. Name all the tools and equipment used.

[4]

- (c) Fig. 17 shows the back of the roof of the bird feeder. The flaps will be pop riveted to the main part of the bird feeder.

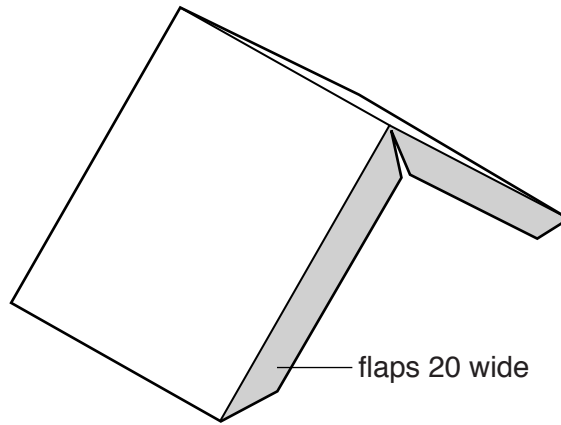

Fig. 17

- (i) Describe how the roof could be attached using pop rivets.

.....
.....
.....
..... [3]

- (ii) Give **one** advantage of using pop riveting rather than the traditional riveting process.

..... [1]

- (d) A container to hold water is required. The position for the container is shown at **X** in Fig. 15. The container will be made from vacuum formed plastic.

- (i) Use sketches and notes to show a design for a vacuum formed plastic container to hold water. Show how the container will be attached to the bird feeder.

(ii) Use sketches and notes to show the mould that will be used to vacuum form the container.

[3]

(iii) Name a suitable plastic for the vacuum formed container.

..... [1]

(e) Use sketches and notes to show a modification to the design of the bird feeder so that it could be suspended from the branch of a tree.
Name all the materials and fittings used.

[3]

BLANK PAGE

Permission to reproduce items where third-party owned material protected by copyright is included has been sought and cleared where possible. Every reasonable effort has been made by the publisher (UCLES) to trace copyright holders, but if any items requiring clearance have unwittingly been included, the publisher will be pleased to make amends at the earliest possible opportunity.

To avoid the issue of disclosure of answer-related information to candidates, all copyright acknowledgements are reproduced online in the Cambridge International Examinations Copyright Acknowledgements Booklet. This is produced for each series of examinations and is freely available to download at www.cie.org.uk after the live examination series.

Cambridge International Examinations is part of the Cambridge Assessment Group. Cambridge Assessment is the brand name of University of Cambridge Local Examinations Syndicate (UCLES), which is itself a department of the University of Cambridge.